

# LabM-I-5

## Programmable IR detection module based on HgCdTe TE cooled optically immersed photovoltaic detector

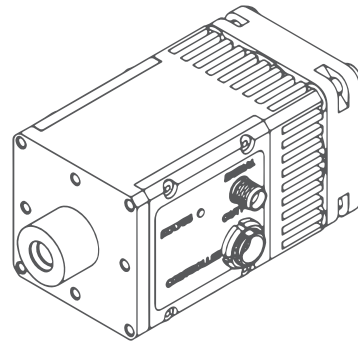

### FEATURES

- Spectral range: 2.7 to 5.6  $\mu\text{m}$
- Frequency bandwidth: DC to 18 MHz (typ.)
- High performance and reliability
- DC offset compensation
- Built-in fan
- M4 mounting hole
- Compatible with optical accessories
- Versatility and flexibility
- Quantity discounted price
- Fast delivery
- No minimum order quantity required

### APPLICATIONS

- Contactless temperature measurement: railway transport, industrial and laboratory processes monitoring
- Flame and explosion detection
- Threat warning systems
- Heat-seeking, thermal signature detection
- Dentistry
- Gas detection, monitoring and analysis:  $\text{CH}_4$ ,  $\text{C}_2\text{H}_2$ ,  $\text{CH}_2\text{O}$ ,  $\text{HCl}$ ,  $\text{NH}_3$ ,  $\text{SO}_2$ ,  $\text{C}_2\text{H}_6$ ,  $\text{CO}$ ,  $\text{CO}_2$ ,  $\text{NO}_x$
- Breath analysis:  $\text{C}_2\text{H}_6$ ,  $\text{CH}_2\text{O}$ ,  $\text{NH}_3$ ,  $\text{NO}$ ,  $\text{OCS}$
- Gas leak detection
- Combustion process control
- Non-destructive material testing
- Research and prototyping

### PROGRAMMABLE PARAMETERS

- Gain: in the 40 dB range
- Bandwidth: 0.15 MHz/1.5 MHz/18 MHz (typ.)
- Coupling: AC/DC
- Detector's temperature
- Output voltage offset

### INCLUDED ACCESSORIES

- 1 pc of SMA-BNC cable
- 1 pc of LEMO-DB9 cable

### DEDICATED ACCESSORIES

- PTCC-01 TEC controller series: obligatory (p. 145)
- Smart Manager software: freeware
- OTA optical threaded adapter (p. 155)
- DRB-2 base mounting system (p. 152)

### DETECTION MODULE CONFIGURATION

Detection module symbol	LabM-I-5
Detector symbol	PVI-2TE-5-1x1-TO8-wAl <sub>2</sub> O <sub>3</sub> -36 (p. 35)
Detector type	photovoltaic
Active element material	epitaxial HgCdTe heterostructure
Optical area, A <sub>o</sub>	1 mm × 1 mm
Immersion	hyperhemisphere
Cooling	2TE
Acceptance angle, $\Phi$	~36 deg.
Window	wAl <sub>2</sub> O <sub>3</sub> (3 deg. wedged sapphire)
Preamplifier symbol	PIP (p. 129)
Preamplifier type	transimpedance, programmable
Signal output socket	SMA
Power supply, TE cooler, thermistor and fan socket	LEMO ECG.0B.309.CLN

SPECIFICATION ( $T_{amb} = 293\text{ K}$ ,  $R_{load} = 50\ \Omega$ , unless otherwise noted; default module settings)

Parameter	Test conditions/remarks	Value			Unit
		Min.	Typ.	Max.	
Active element temperature, $T_{chip}$		-	230	-	K
Cut-on wavelength, $\lambda_{cut-on}$ (10%)	At 10% of the peak responsivity	-	2.7	-	$\mu\text{m}$
Peak wavelength, $\lambda_{peak}$		4.2	4.4	4.6	$\mu\text{m}$
Specific wavelength, $\lambda_{spec}$		-	5.0	-	$\mu\text{m}$
Cut-off wavelength, $\lambda_{cut-off}$ (10%)	At 10% of the peak responsivity	-	5.6	-	$\mu\text{m}$
Detectivity, $D^*$	At $\lambda = \lambda_{peak}$ , $f = 1\text{ MHz}$	-	$2.8 \times 10^{10}$	-	$\text{cm}\cdot\text{Hz}^{1/2}/\text{W}$
	At $\lambda = \lambda_{spec}$ , $f = 1\text{ MHz}$	$1.0 \times 10^{10}$	$1.6 \times 10^{10}$	-	$\text{cm}\cdot\text{Hz}^{1/2}/\text{W}$
Output noise voltage density, $v_n$	At $f = 1\text{ MHz}$	-	-	500	$\text{nV}/\text{Hz}^{1/2}$
Voltage responsivity, $R_v$	At $\lambda = \lambda_{peak}$	-	$7.9 \times 10^4$	-	$\text{V}/\text{W}$
	At $\lambda = \lambda_{spec}$	$3.0 \times 10^4$	$4.6 \times 10^4$	-	$\text{V}/\text{W}$
Low cut-off frequency, $f_{lo-DC}$	DC coupling selected	-	0	-	Hz
Low cut-off frequency, $f_{lo-AC}$	AC coupling selected	-	10	-	Hz
High cut-off frequency, $f_{hi-H}$	High bandwidth selected	12	18	-	MHz
High cut-off frequency, $f_{hi-M}$	Mid bandwidth selected	-	1.5	-	MHz
High cut-off frequency, $f_{hi-L}$	Low bandwidth selected	-	0.15	-	MHz
Output impedance, $R_{out}$		-	50	-	$\Omega$
Output voltage swing, $V_{out}$		-	-	$\pm 1$	V
Output voltage offset, $V_{off}$		-	-	$\pm 20$	mV
Power supply voltage (positive), $+V_{sup}$		-	+9	-	V
Power supply voltage (negative), $-V_{sup}$		-	-9	-	V
Power supply current consumption (positive), $+I_{sup}$		-	-	+100	mA
Power supply current consumption (negative), $-I_{sup}$		-	-	-100	mA
Fan power consumption, $P_{fan}$		-	-	900	mW
TEC voltage, $V_{TEC}$		-	-	1.3	V
TEC current, $I_{TEC}$		-	-	1.2	A
Weight		-	180	-	g

SPECTRAL RESPONSE (Typ.,  $T_{amb} = 293\text{ K}$ ,  $T_{chip} = 230\text{ K}$ )

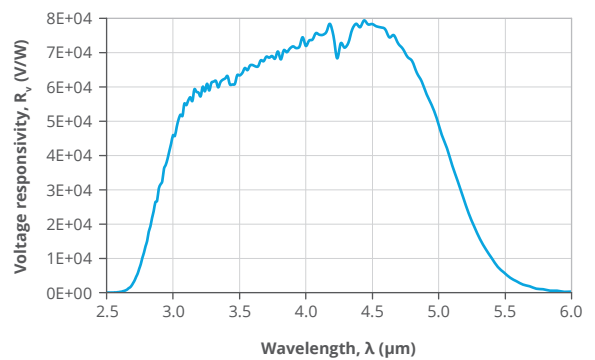
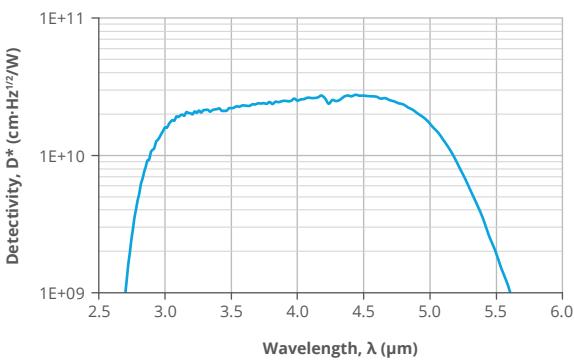

## MECHANICAL LAYOUT (Unit: mm)

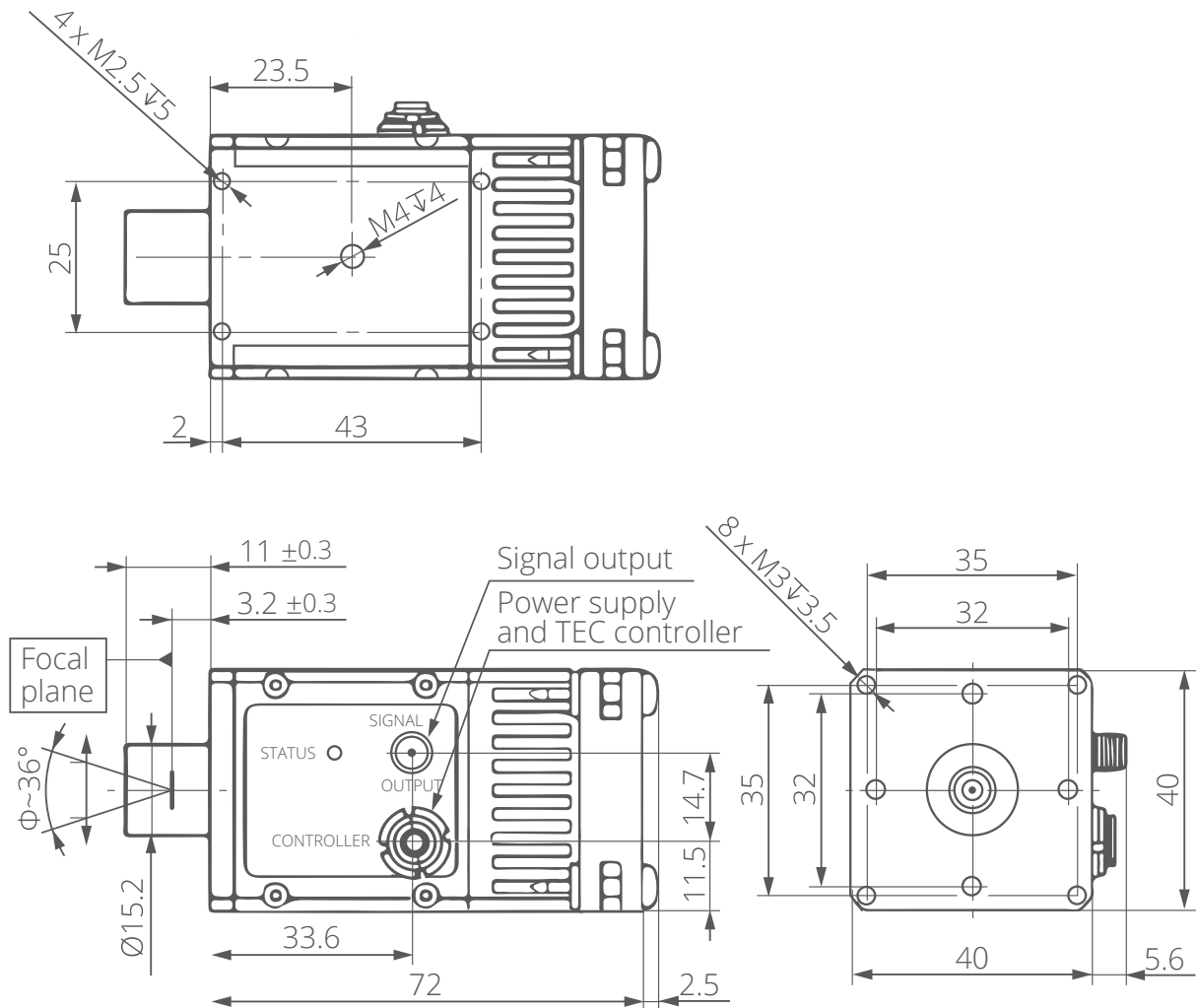

## SCHEMATIC DIAGRAM

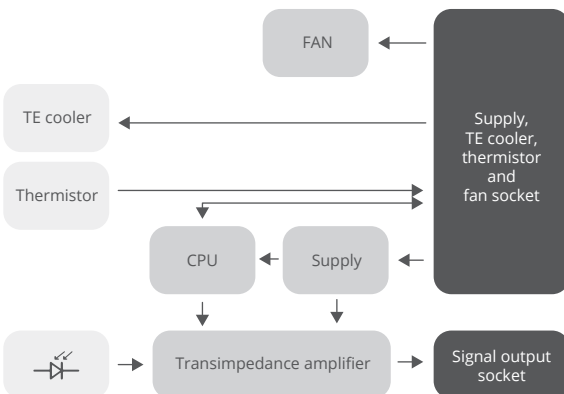

## ABSOLUTE MAXIMUM RATINGS

Parameter	Test conditions/remarks	Value	Unit
Ambient operating temperature, $T_{amb}$		10 to 30	°C
Storage temperature, $T_{stg}$		-20 to 50	°C
Humidity	No dew condensation	10 to 90	%
Maximum incident optical power density	Continuous wave (CW) or single pulses >1 $\mu$ s duration	2.5	W/cm <sup>2</sup>
	Single pulses <1 $\mu$ s duration	10	kW/cm <sup>2</sup>

Stresses beyond those listed under absolute maximum ratings may cause permanent damage to the device. Constant or repeated exposure to absolute maximum rating conditions may affect the quality and reliability of the device.